

A hands on Introduction To Resin Transfer Moulding 24-26 April 2012

The National Aerospace Laboratory NLR is one of the leading institutes within Europe in bringing the potentials of Resin Transfer Moulding (RTM) into practice. Numerous technology development programmes, in which RTM components were developed in close collaboration with industry were carried out successfully. Examples are the development of composite fuselage frames and composite landing gear components.

This course offers a broad introduction to Resin Transfer Moulding as manufacturing method for composite components for the aerospace industry.

There is a high practical content. Participants will spend time in the laboratory, where they will manufacture pre-forms using different techniques, carry out permeability experiments to visualise flow fronts and manufacture flat plates with different Resin Transfer Moulding techniques.

The course is appropriate for designers, engineers and managers with little or no experience on Resin Transfer Moulding.

Course fee includes refreshments, lunches and course notes.
Course language is English.

Due to the experiments carried out in the composites laboratory the course is limited to twelve delegates per course.

Programme

The course begins on a Tuesday and ends on a Thursday.

Tuesday, day 1

- 09:00 Registration
- 09:15 Introduction to composite activities of the National Aerospace Laboratory NLR
- 09:30 *Basic principles of Resin Transfer Moulding- Pressurised RTM, Vacuum assisted RTM, comparison to traditional autoclave curing*
- 10:30 Coffee
- 10:45 *Resins and reinforcements for composites – types, forms, pre-forming concepts, manufacturing considerations and selection criteria*
- 12:15 Lunch
- 13:15 *Simulation of resin injection – I, generation of input parameters, resin viscosity and permeability of reinforcements*
- 14:45 Coffee
- 15:00 *Practical I: Determination of resin viscosity and permeability experiments*
- 16:30 End of day one

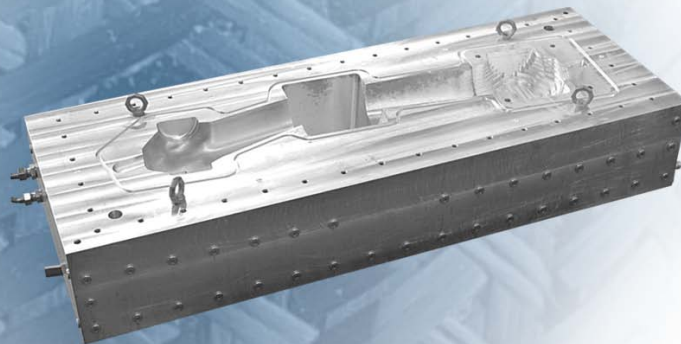

Wednesday, day 2

- 09:00 *Practical I: Determination of resin viscosity and permeability experiments*
- 10:30 Coffee
- 10:45 *Simulation of resin injection – II*
- 12:15 Lunch
- 13:15 *RTM tooling concepts*
- 14:15 Coffee
- 14:30 *Practical II: Manufacturing of pre-forms- Preparation*
- 15:15 *Practical II: Manufacturing of pre-forms*
- 16:45 Guided tour of testing facilities (optional)
- 17:30 End of day two



Thursday, day 3

- 09:00 *Practical III: Manufacturing of flat plates – pressurised RTM with matched die or vacuum assisted RTM*
- 10:15 Coffee
- 10:30 *RTM design for manufacturing guidelines*
- 12:00 Start case study
- 12:15 Lunch
- 13:30 Case study bringing course content into practice
- 15:45 Presentations case study
- 16:15 Results from injection
- 16:45 Wrap-up
- 17:15 End of the course

A hands on Introduction To Resin Transfer Moulding

24-26 April 2012



*For more information or a registration form,
please contact:*

National Aerospace Laboratory NLR
Ms. Ineke van Wijk
P.O. Box 153
8300 AD EMMELOORD
The Netherlands
Tel. : +31 88 511 44 50
Fax : +31 88 511 42 10
E-mail : Ineke.van.Wijk@nlr.nl

Location

NLR Flevoland
Voorsterweg 31
8316 PR MARKNESSE
Tel. +31 88 511 44 44
www.nlr.nl

The NLR Flevoland site is located at 1 hour and
15 minutes by car from Amsterdam Airport.

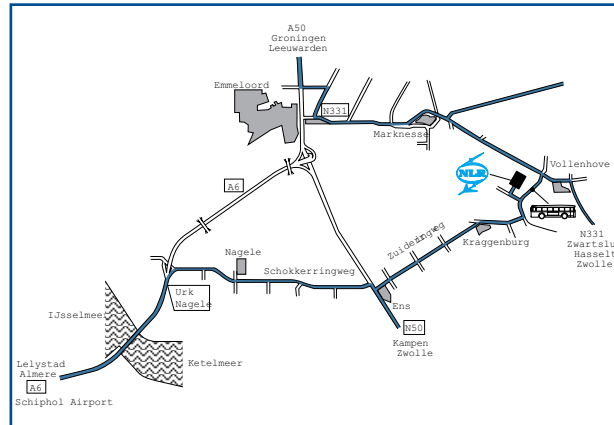

From Schiphol take the A4 direction Amsterdam;
At junction "Badhoevedorp" take the A9 direction Utrecht;
At junction "Holendrecht" take the A2 direction Almere;
Then take the A9 again direction Almere;
Then the A1 direction Almere;
Then the A6 direction Almere;
Follow the A6 direction Lelystad;
Follow the A6 direction Emmeloord;
Then follow instructions on the map above.

Nationaal Lucht- en Ruimtevaartlaboratorium
National Aerospace Laboratory NLR



A hands on Introduction To Resin Transfer Moulding

Professional Development and Training

24-26 April 2012



Aerospace Vehicles Division
Structures Technology Department